

COFFMAN SYSTEMS, INC.

WATER, WASTE & INDUSTRIAL PROCESS EQUIPMENT
SALES - ENGINEERING - SERVICE

DUST COLLECTOR MODEL 70-02

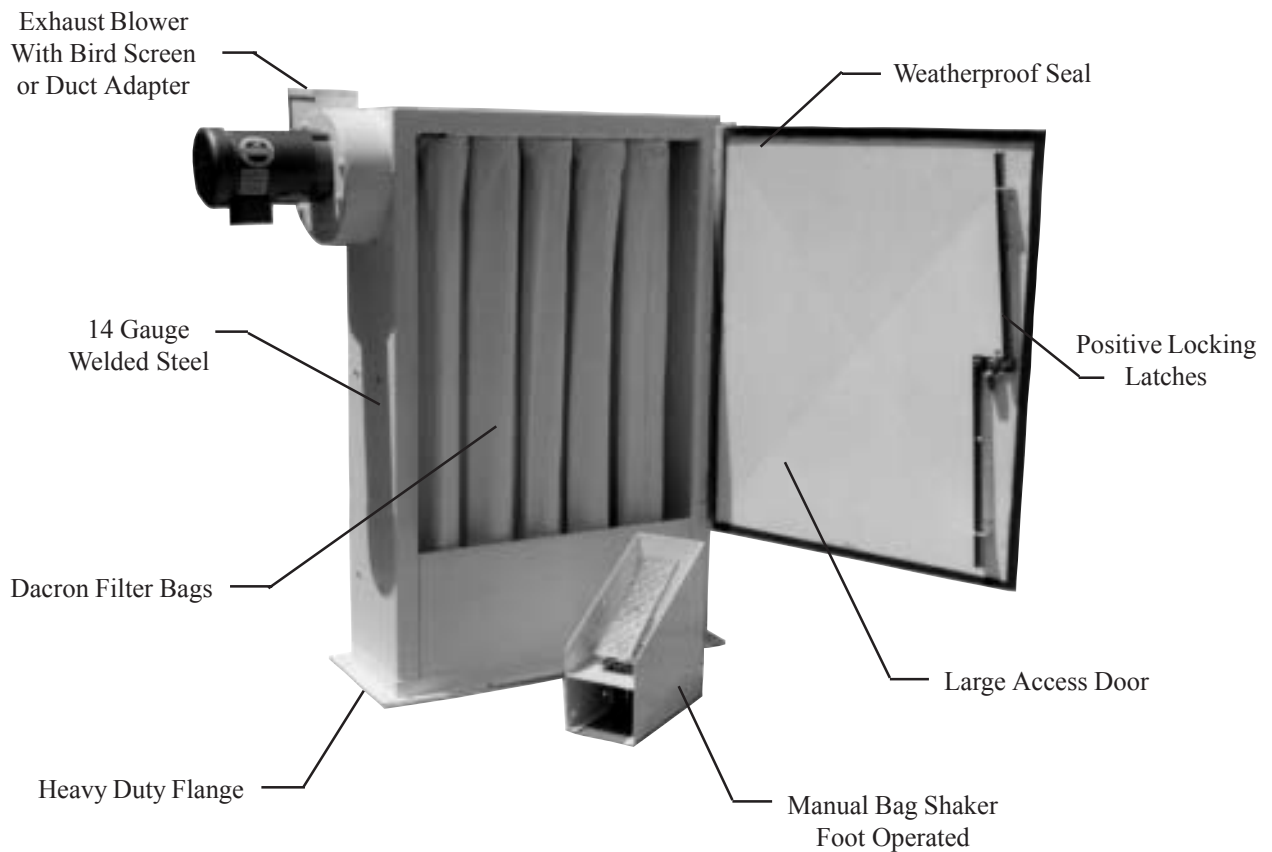

Standard Features

- Superior capture capabilities with 99.9% efficiency
- Heavy duty construction - optional 316 stainless steel
- Slim design allows mounting directly over bin, hopper, etc.
- 400 cfm with a 1725 rpm fan speed
- 600 cfm with a 3450 rpm fan speed

Note: Unit shown is epoxy coated steel.

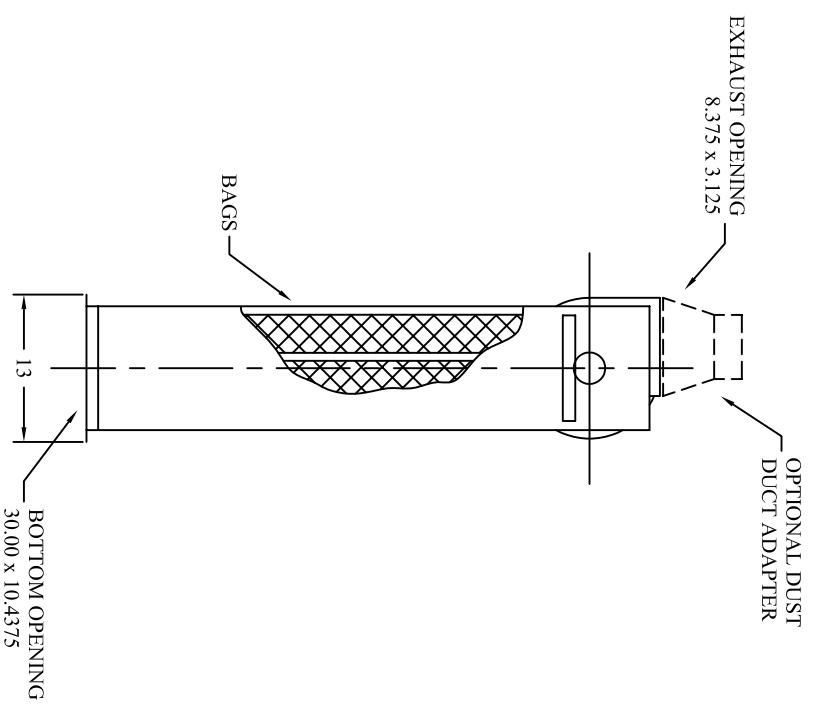
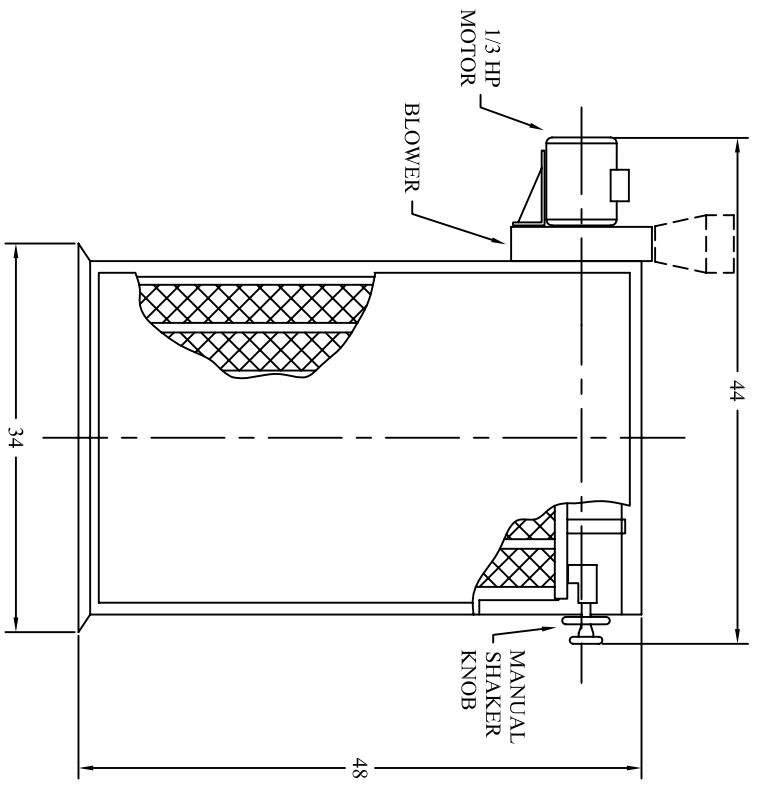
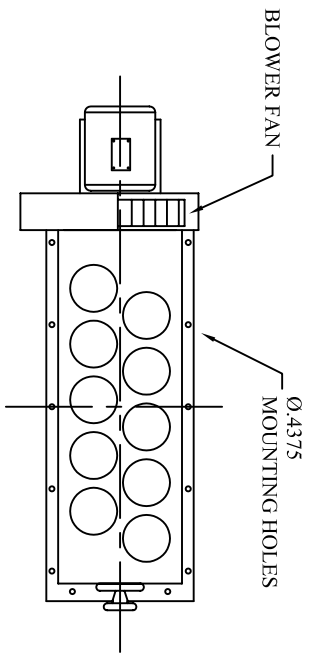

70 SERIES DUST COLLECTOR

FILTER CAPACITY

MODEL NO.	CFM RATING W/DUCT	CFM RATING W/NO DUCT	NO. OF BAGS	MOTOR HP	MOTOR RPM	CLOTH AREA
70-01	75	400	10	1/3	1725	35 SQ FT
70-02	300	600	10	1	3450	35 SQ FT