

COFFMAN SYSTEMS, INC.

WATER, WASTE & INDUSTRIAL PROCESS EQUIPMENT
SALES - ENGINEERING - SERVICE

CHEMICAL DISSOLVER TANK

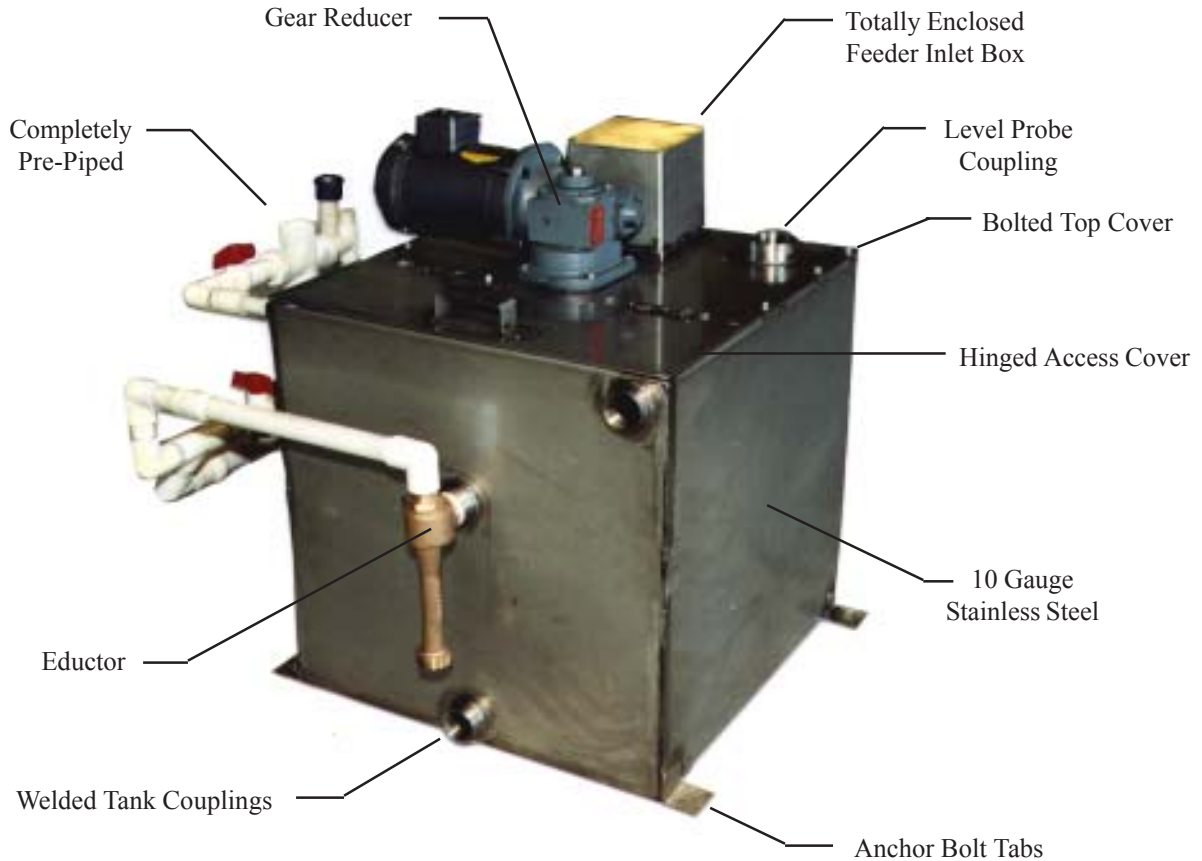

Standard Features

- Superior dissolving capabilities with internal mixing jets
- Heavy duty construction - optional 316 stainless steel
- Top mounted slow speed turbine mixer
- Stainless steel mixing shaft and blades
- Sloped tank bottom for easy cleanout

Note: Unit shown is 316 stainless steel.

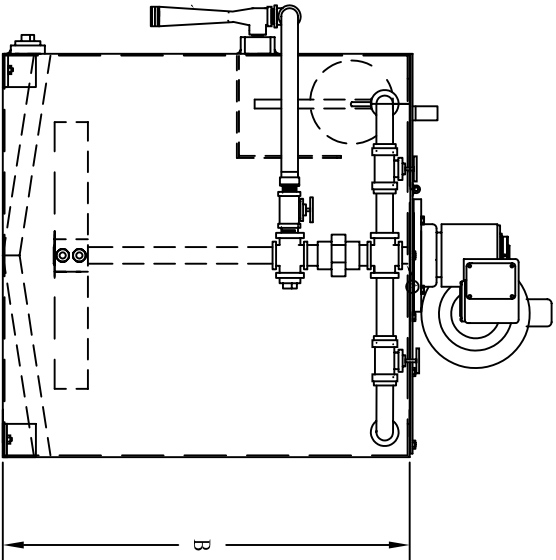
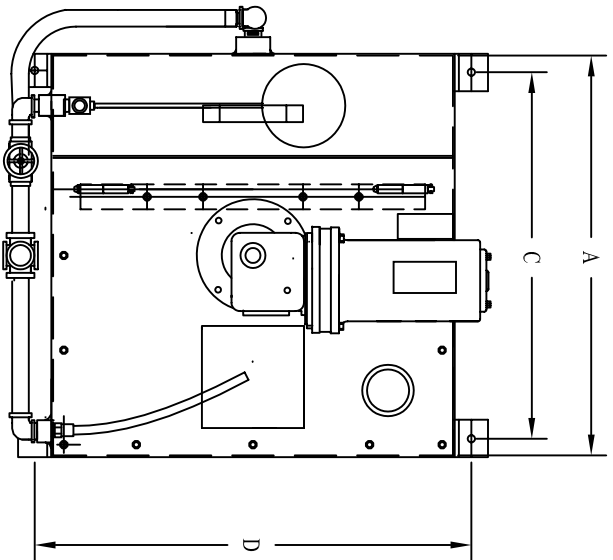

CHEMICAL DISSOLVER TANK

MODEL NO.	CAPACITY (GALS.)	DIMENSIONS (IN.)				
		A	B	C	D	E
50-01	50	30.00	27.00	28.00	32.00	3/4
50-02	100	36.00	36.00	34.00	38.00	3/4
50-03	200	42.00	45.00	40.00	44.00	1
50-04	400	48.00	57.00	46.00	50.00	1-1/2
50-05	600	60.00	54.00	58.00	62.00	2
50-06	800	66.00	57.00	64.00	68.00	2
50-07	1000	66.00	66.00	64.00	68.00	2

