

# COFFMAN SYSTEMS, INC.

WATER, WASTE & INDUSTRIAL PROCESS EQUIPMENT  
SALES - ENGINEERING - SERVICE

## CHEMICAL FEED SYSTEM

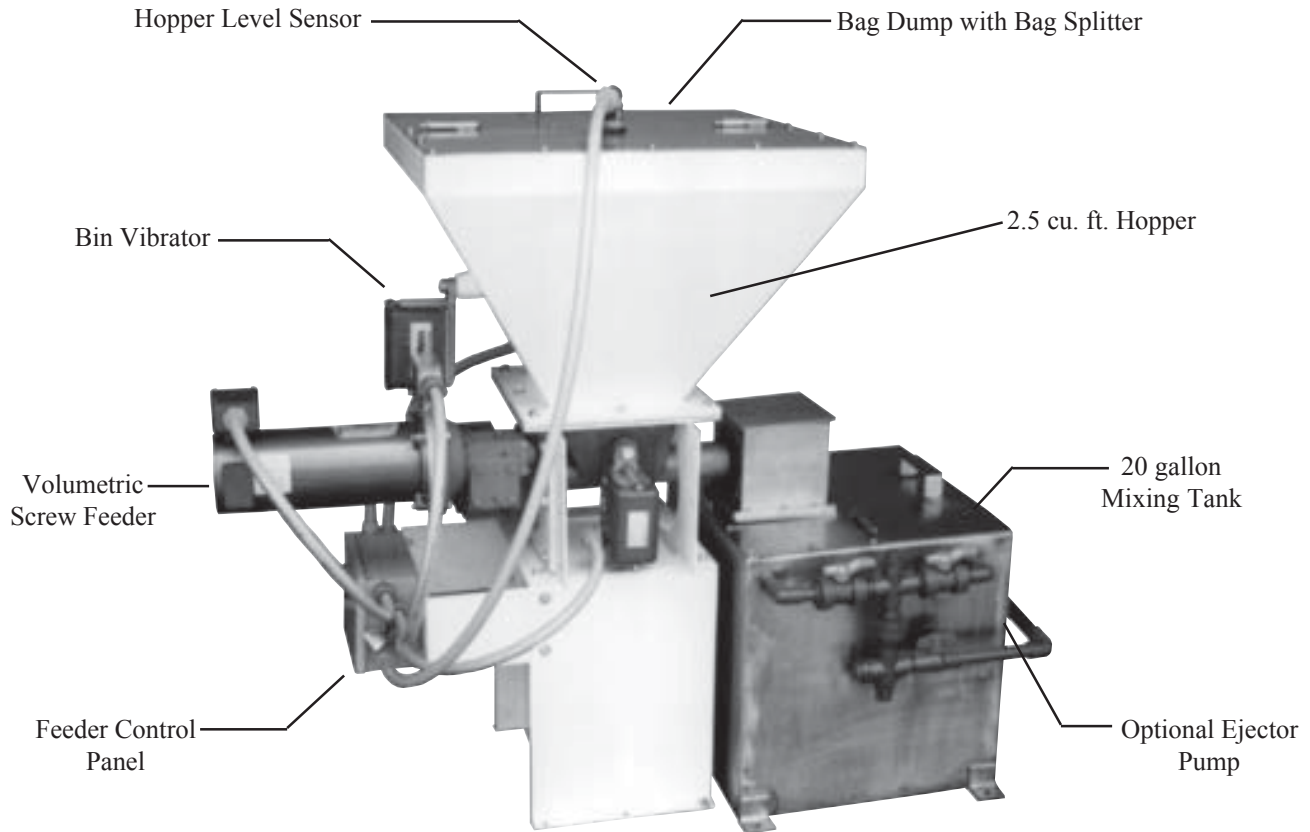

### Standard Features

- 25-01 Screw Feeder with AC or DC Variable Speed Drive
- 20 gallon Mixing Tank with water jet Mixer
- 24" x 24" Hopper (2.5 cu. ft.) Heavy Duty Construction
- Complete Automatic or Manual Control
- Hopper Level Sensors

**NOTE: Shipped Completely Assembled and Ready for Hookup to Power and Water.**

# CHEMICAL FEED SYSTEM

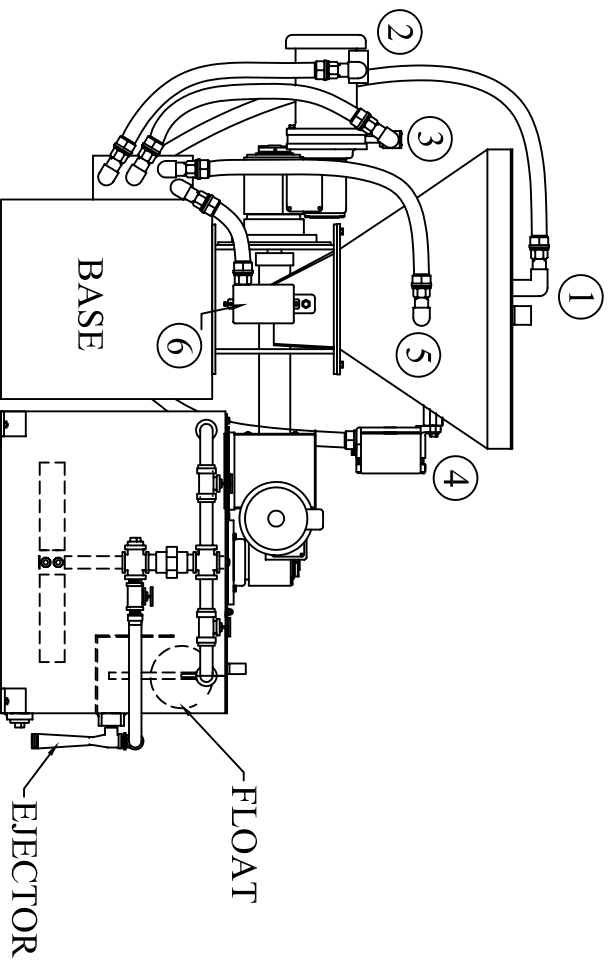
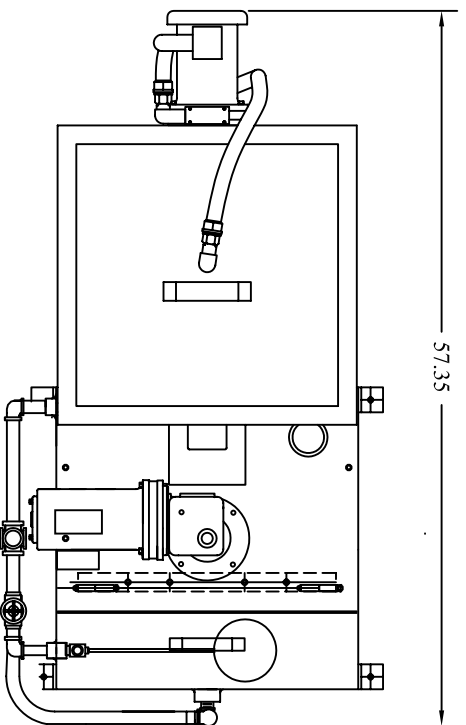

- 1. HOPPER SENSOR
- 2. MOTOR POWER
- 3. PULSE RING
- 4. HOPPER VIBRATOR
- 5. LOW LEVEL SENSOR
- 6. FEEDER VIBRATOR

