

# COFFMAN SYSTEMS, INC.

WATER, WASTE & INDUSTRIAL PROCESS EQUIPMENT  
SALES - ENGINEERING - SERVICE

## CHEMICAL FEED SYSTEM

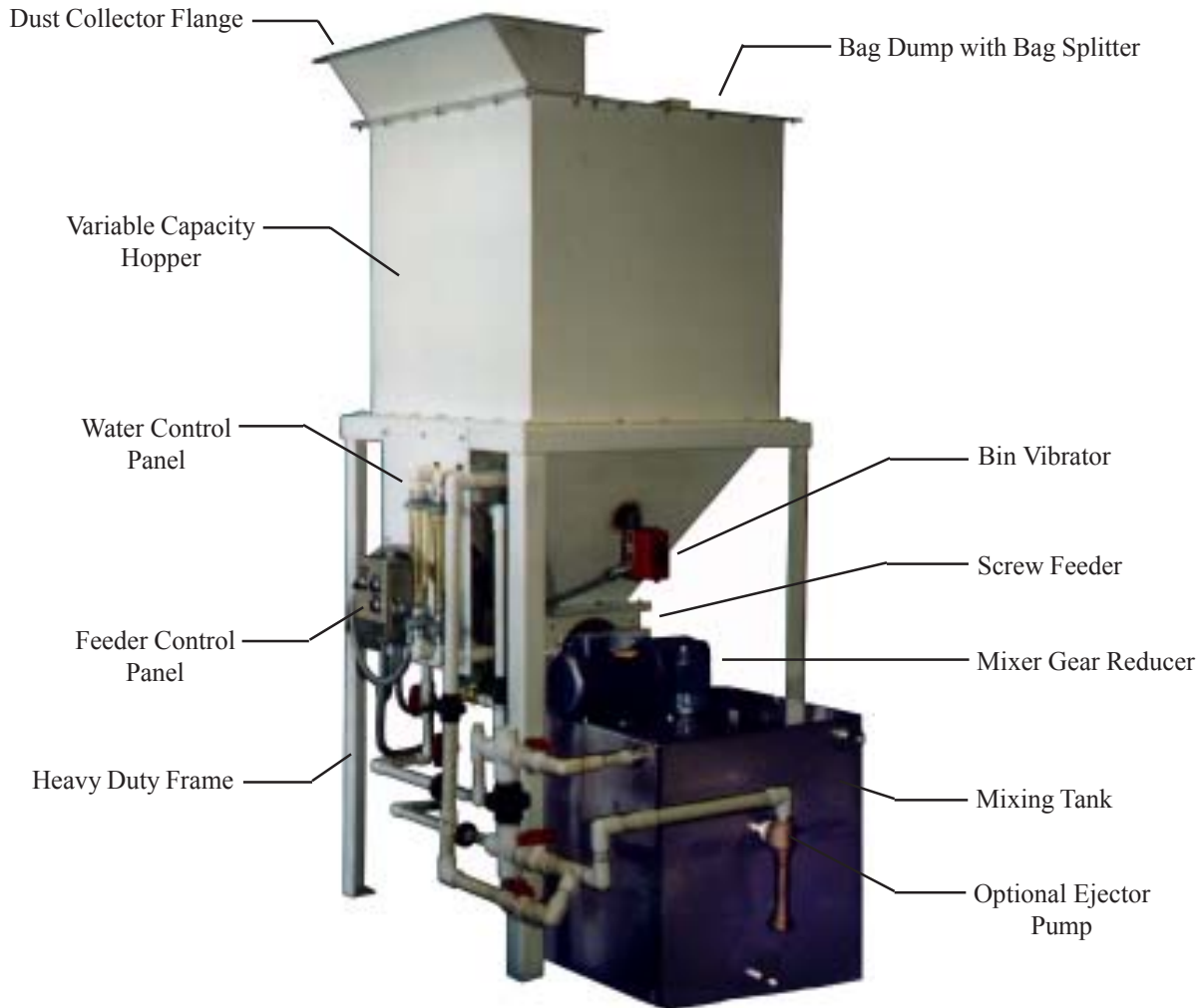

### Standard Features

- 25-01 Screw Feeder with AC or DC Variable Speed Drive
- 50 gallon Mixing Tank with Top Mounted Slow Speed Turbine Mixer
- 30" x 30" Hopper (variable capacity) Heavy Duty Construction
- Complete Automatic or Manual Control
- Dust Collector model 70-02 (not shown)

**NOTE: Shipped Completely Assembled and Ready for Hookup to Power and Water.**

# CHEMICAL FEED SYSTEM

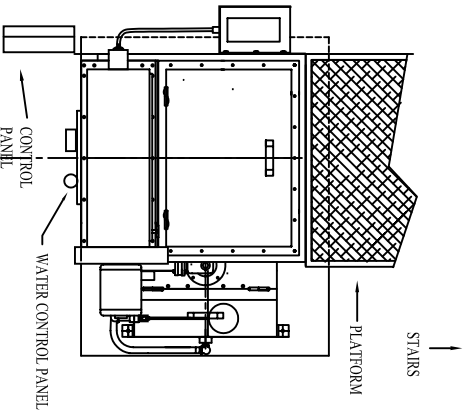

1. CSI DUST COLLECTOR
2. EXHAUST DUCT
3. FAN MOTOR
4. MANUAL BAG SHAKER
5. ACCESS DOOR TO FILTER BAGS
6. HOPPER HINGED COVER
7. BAG DUMP SINK
8. BAG SPLITTER
9. STORAGE HOPPER VARIABLE SIZES
10. FLOOR SUPPORTS
11. HOPPER VIBRATOR
12. CSI 25-01 SCREW FEEDER
13. DISSOLVER TANK
14. CSI TURBINE MIXER
15. SAMPLE CHUTE
16. LEVEL PROBE
17. FLOAT VALVE
18. EJECTOR

