

COFFMAN SYSTEMS, INC.

WATER, WASTE & INDUSTRIAL PROCESS EQUIPMENT
SALES - ENGINEERING - SERVICE

BULK BAG UNLOADING SYSTEM

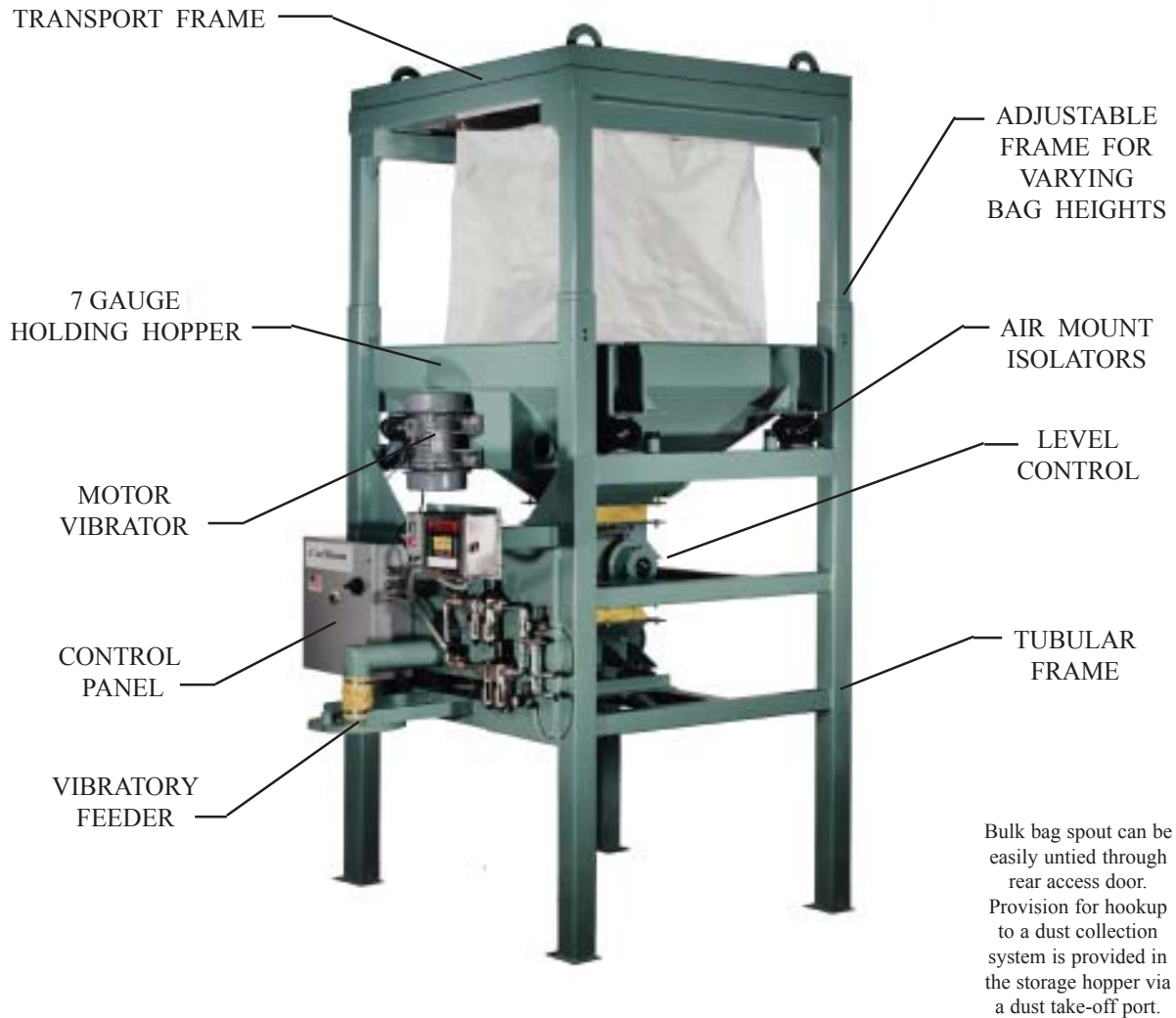

Standard Features

- maximum 42" square x 60" tall bulk bag with loads up to 4000 Lbs.
- Lift out bag transport frame with safety clips
- Quite 3/4 HP motor vibrator for hopper with airmount isolators
- Dust tight access port for bag untie
- Heavy 7 gage construction with 4" square tubular legs

Note: Unit shown with optional feeder.

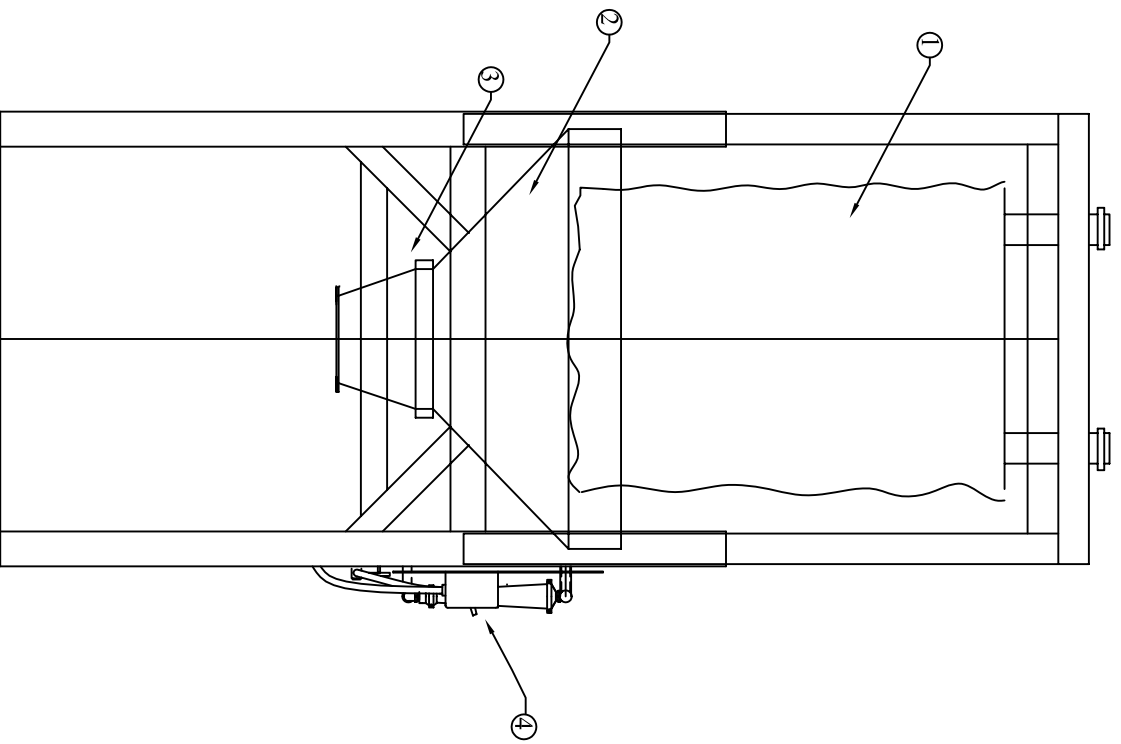
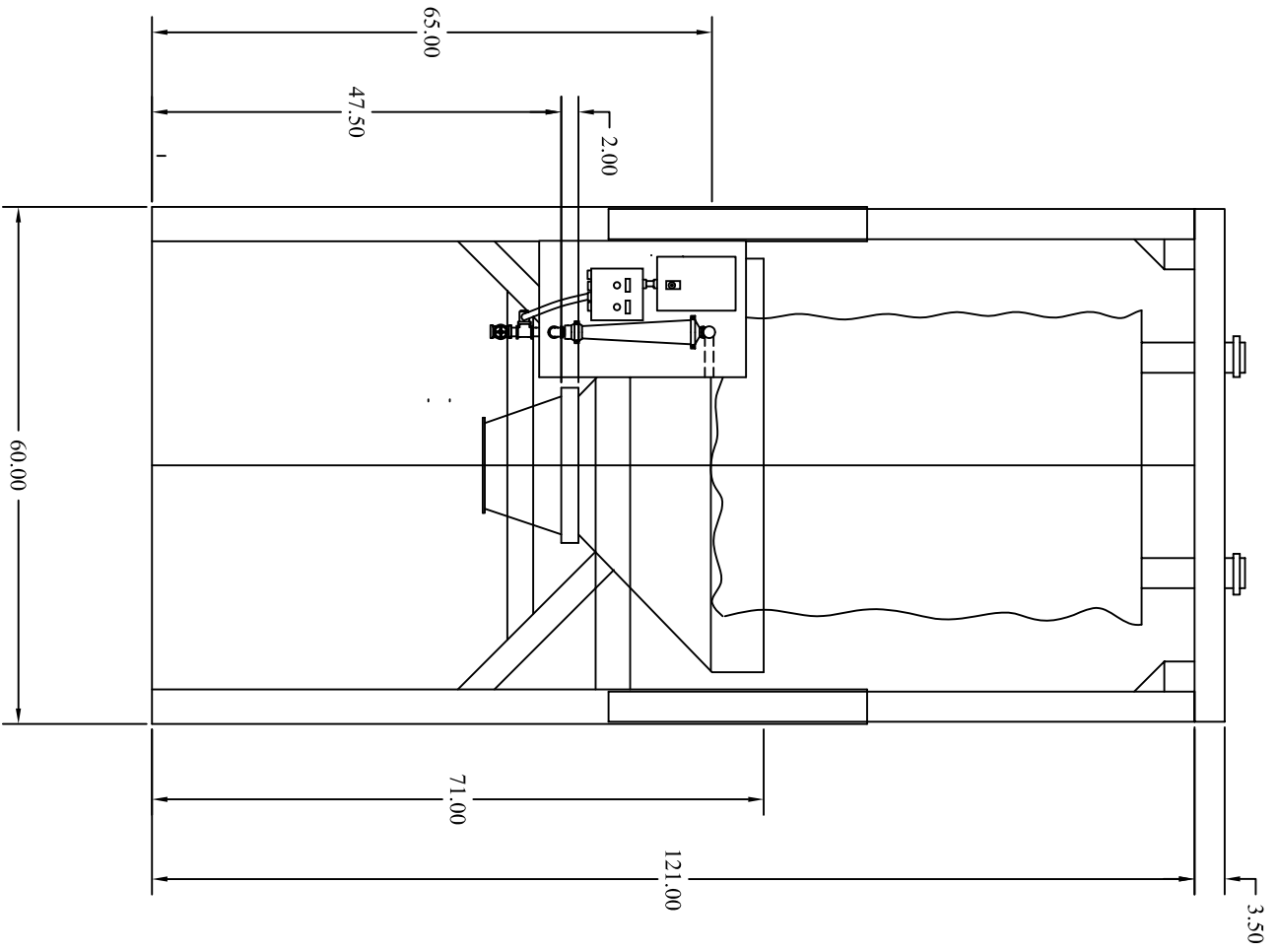

- 1. 1 TON BULK BAG
- 2. VIBRATING BIN ACTIVATOR
- 3. TRANSITION HOPPER
- 4. SYSTEM CONTROL PANEL