

COFFMAN SYSTEMS, INC.

WATER, WASTE & INDUSTRIAL PROCESS EQUIPMENT
SALES - ENGINEERING - SERVICE

UNIVERSAL SCREW FEEDER Model 25-01

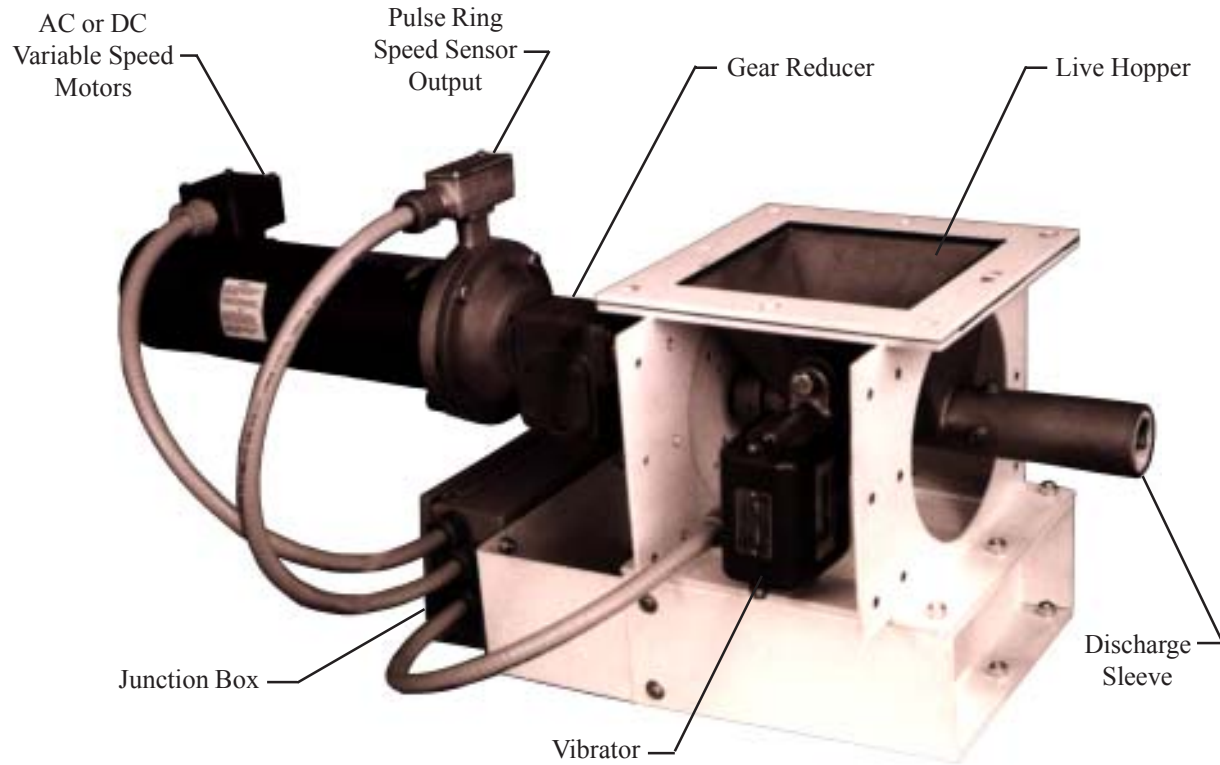

Volumetric Dry Materials Screw Feeder

Standard Features

- Heavy Duty, dust tight construction, optional stainless steel
- Heavy duty gear reducer, variable speed direct drive
- 1 to 20 cubic feet per hour feed rate
- Accuracy of +/- 1% by volume or 2 to 5 % by weight
- 8 inch square inlet inside, 12 inch square flange

Note: Unit shown with vibrating live hopper and discharge sleeve

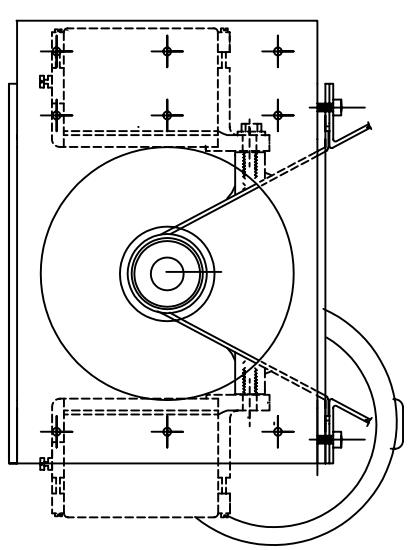
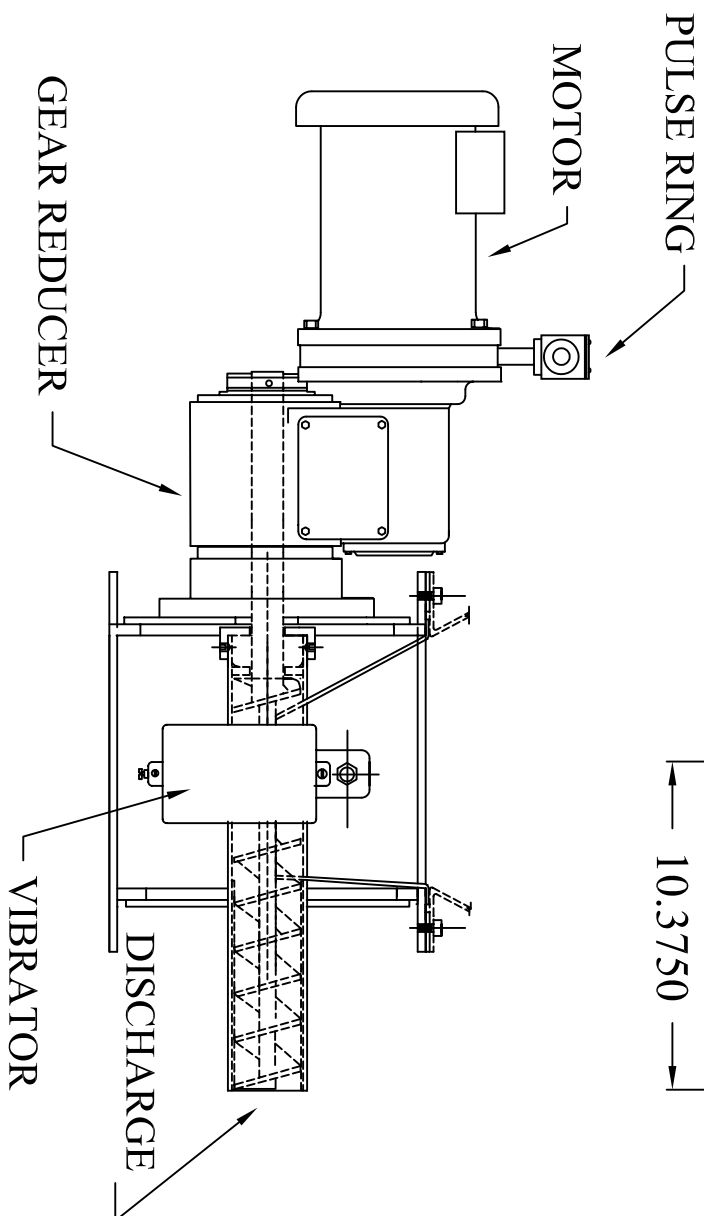
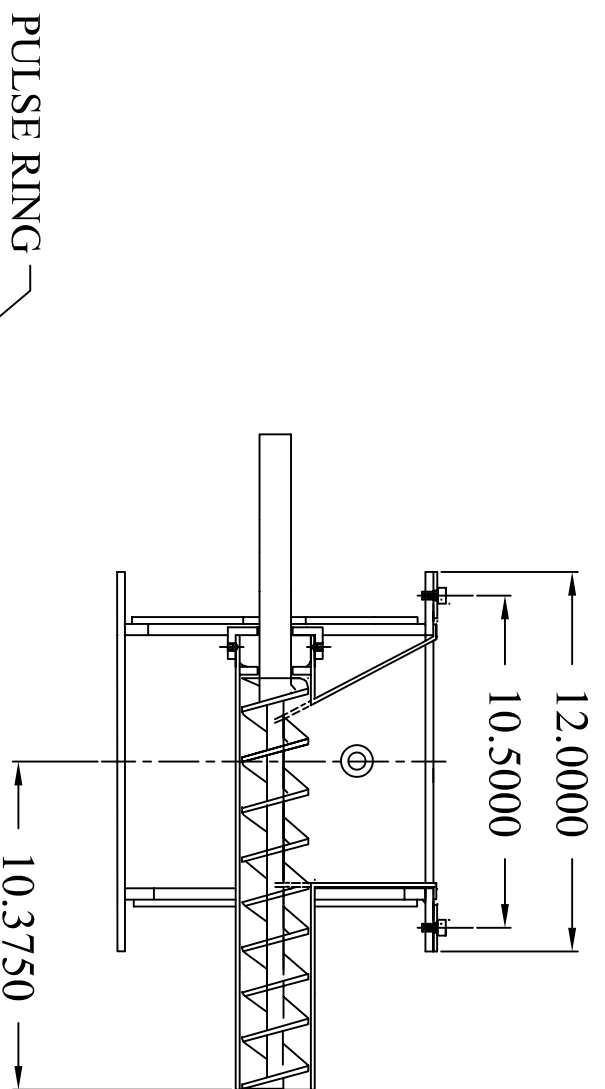

UNIVERSAL SCREW FEEDER

CONTROLS

- * MANUAL: from Local Rate Setter or SCR
- * REMOTE: from Remote Mounted Potentiometer or 0-20 MA Transmitter signal.
- * Ratio Control: may be arranged for automatic proportional control from Plant or process meter signal.